



MOTOROLA

Consumer Systems Group

Order this document by
MCF5206e/D

MCF5206e

Product Brief MCF5206e Integrated Microprocessor

OVERVIEW

Introduction

The MCF5206e integrated microprocessor combines a ColdFire[®] core with several peripheral functions such as a DRAM controller, timers, parallel and serial interfaces, and system integration. This device is an enhanced version of the MCF5206, which is in production today. Not only does the MCF5206e provide a performance upgrade to the MCF5206 due to the increased 4 KByte Icache and 8 KByte SRAM and increased frequency, but this device also integrates an additional Multiply Accumulate (MAC) unit, hardware divide, and two-channel DMA to the device while maintaining pin compatibility with the MCF5206.

The revolutionary ColdFire architecture gives cost-sensitive, high-volume markets new levels of price and performance. Based upon the concept of variable-length RISC technology, the ColdFire core combines the architectural simplicity of conventional 32-bit RISC with a memory-saving, variable-length instruction set. In defining the ColdFire architecture for embedded processing applications, Motorola incorporated RISC architecture for peak performance and a simplified version of the variable-length instruction set found in the M68000 Family for code density.

By using a variable-length instruction set architecture, embedded processor designers using ColdFire processors will enjoy significant system-level advantages over conventional fixed-length RISC architectures. The denser binary code for ColdFire processors consumes less valuable memory than fixed-length instruction set RISC processors available. This improved code density means more efficient system memory usage for a given application, and allows for slower, less costly memory to help achieve a target price/performance level

¹. I²C bus is a proprietary Philips interface bus.

SEMICONDUCTOR PRODUCT INFORMATION

Introduction, Continued

Introduction (Continued)

Designed for embedded control applications, the MCF5206e Version 2 core delivers enhanced performance while maintaining low system costs. The addition of a MAC module and hardware divide to the core increases performance of complex arithmetic functions normally used in DSP applications. To speed program execution, the onchip instruction cache and SRAM provides one-cycle access to critical code and data. The MCF5206e processor greatly reduces the time required for system design and implementation by packaging common system functions on chip and providing glueless interfaces to 8 bit, 16 bit and 32 bit DRAM, SRAM, ROM, and I/O devices.

The integrated peripheral functions provide high performance and flexibility. The DRAM controller supports as much as 512 Mbytes of DRAM. The MCF5206e processor supports both fast page-mode and extended-data-out DRAMs. The DMA controller provides two fully programmable channels that support both single and dual addressing modes. The serial interfaces consists of two independent UARTs and a separate I²C-compatible¹ Motorola bus (M-Bus interface). Two 16-bit general-purpose multimode timers provide separate input and output signals. For system protection, the processor includes a programmable 16-bit software watchdog timer and several bus monitors. In addition, common system functions such as chip-selects, interrupt control, bus arbitration, and IEEE 1149.1 Test (JTAG) support are included.

A sophisticated debug interface supports both background-debug mode and real-time trace. This interface is common to all ColdFire-based processors and allows emulator support across the entire ColdFire Family.

MCF5206e Features

The primary features of the MCF5206e integrated processor include the following:

- ColdFire Version 2 Core
 - Variable-length RISC
 - 32-bit internal address bus with 28-bit external bus; chip select and DRAM decoding use internal 32 bit
 - 32-bit data bus
 - 16 user-visible 32-bit wide registers
 - Supervisor / User modes for system protection
 - Vector base register to relocate exception-vector table

Continued on next page

Introduction, Continued

MCF5206e Features (Continued)

- Optimized for high level language constructs
- 50 MIPS at 54 MHz
- Multiply Accumulate
 - Provides high speed, complex arithmetic functions for signal processing applications
 - 1 clock issue rate with 3-stage execution pipeline
 - Supports 16x16 and 32x32 multiplies, all with 32-bit accumulate
- 4 KByte Direct-Mapped Instruction Cache
- 8 KByte On-Chip SRAM
 - Provides one-cycle access to critical code and data
- DRAM Controller
 - Programmable refresh timer provides CAS-before-RAS refresh
 - Support for 2 separate memory banks
 - Support for fast page mode DRAMs and extended-data-out (EDO) DRAMs
 - Allows external bus master access
- DMA Controller
 - Two fully programmable channels with external request pins
 - Supports dual-address and single address transfers with 32-bit capability
 - Two address pointers per channel that can increment or remain constant
 - 16-bit transfer counter per channel
 - Operand packing and unpacking supported
 - Auto-alignment transfers supported for efficient block movement
 - Supports bursting and cycle steal
 - Provides two clock-cycle internal access
- Two Universal Synchronous/Asynchronous Receiver/Transmitters (UART)
 - Full duplex operation
 - Baud-rate generator
 - Modem control signals available ($\overline{\text{CTS}}$, $\overline{\text{RTS}}$)
 - Processor-interrupt capability
- Dual 16-bit General-Purpose Multimode Timers
 - 8-bit prescaler
 - Timer input and output pins
 - 12 ns resolution with 54 MHz system clock
 - Processor-interrupt capability

Continued on next page

Introduction, Continued

MCF5206e Features (Continued)

- Motorola Bus (M-Bus) Module
 - Interchip bus interface for EEPROMs, LCD controllers, A/D converters, keypads
 - Compatible with industry-standard I²C Bus
 - Master or slave modes support multiple masters
 - Automatic interrupt generation with programmable level
- System Interface
 - Glueless bus interface to 8 bit, 16 bit, and 32 bit DRAM, SRAM, ROM, and I/O devices
 - 8 programmable chip selects
 - Programmable wait states and port sizes
 - Allows external bus masters to access chip selects
 - System protection
 - 16-bit software watchdog timer with prescaler
 - Double bus fault monitor
 - Bus timeout monitor
 - Spurious interrupt monitor
 - Programmable interrupt controller
 - Low interrupt latency
 - 3 external interrupt inputs
 - Programmable interrupt priority and autovector generator
 - IEEE 1149.1 test (JTAG) support
 - 8-bit general-purpose I/O interface
- System Debug Support
 - Real-time trace
 - Background debug interface
- Fully Static 3.3-Volt Operation w/ 5-Volt tolerant inputs
- 160 Pin QFP Package - Pin-compatible with MCF5206

MCF5206e Overview

Figure 1 is a block diagram of the MCF5206e processor. The paragraphs that follow provide an overview of the integrated processor.

MCF5206e Overview, Continued

Figure 1: MCF5206e Block Diagram

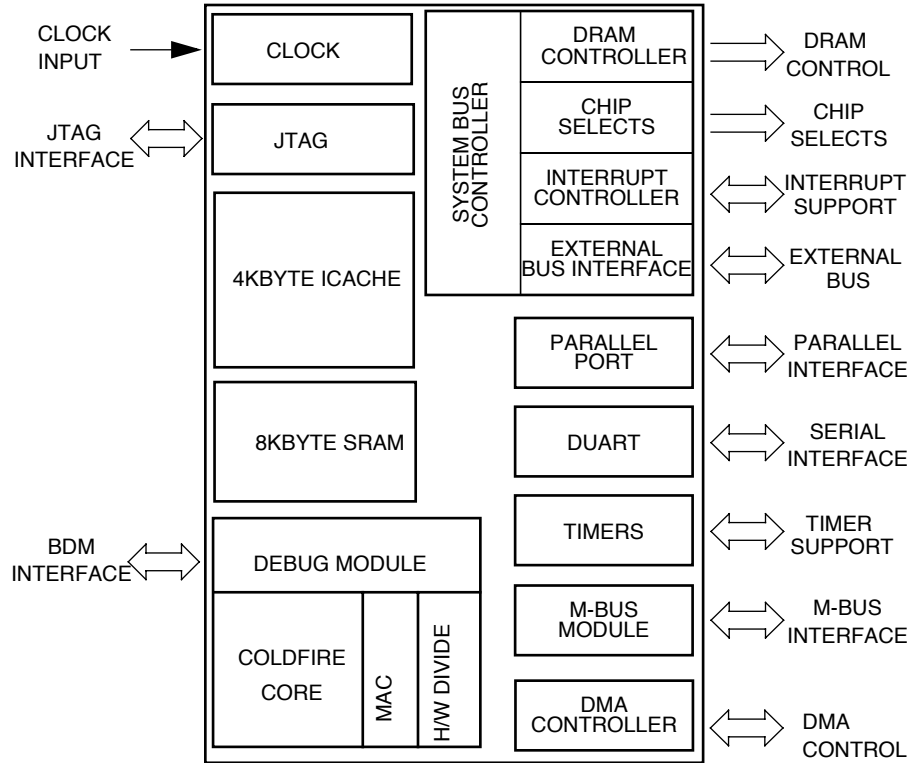

ColdFire Core

The ColdFire processor core consists of two independent, decoupled pipeline structures to maximize performance while minimizing core size. The instruction fetch pipeline (IFP) is a two-stage pipeline for prefetching instructions. The prefetched instruction stream is then gated into the two-stage operand execution pipeline (OEP), which decodes the instruction, fetches the required operands and then executes the required function. Because the IFP and OEP pipelines are decoupled by an instruction buffer that serves as a FIFO queue, the IFP can prefetch instructions in advance of their actual use by the OEP, thereby minimizing time stalled waiting for instructions. The OEP is implemented in a two-stage pipeline featuring a traditional RISC datapath with a dual-read-ported register file feeding an arithmetic/logic unit.

MCF5206e Overview, Continued

Instruction Cache The instruction cache improves system performance by providing cached instructions to the execution unit in a single clock. The MCF5206e processor uses a 4 KByte, direct-mapped instruction cache to achieve 50 MIPS at 54 MHz. The cache is accessed by physical addresses, where each 16 Byte line consists of an address tag and a valid bit.

The instruction cache also includes a bursting interface for 32 bit, 16 bit, and 8 bit port sizes to quickly fill cache lines.

Internal SRAM The 8 Kbyte onchip SRAM provides one clock-cycle access for the ColdFire core. This SRAM can store processor stack and critical code or data segments to maximize performance.

DRAM Controller The MCF5206e DRAM controller provides a glueless interface for up to 2 banks of DRAM, each of which can be as large as 128 KBytes up to 256 MBytes. The controller supports an 8-, 16-, or 32-bit data bus. A unique addressing scheme allows for increases in system memory size without rerouting address lines and rewiring boards. The controller operates in fast page mode, burst-page mode, regular mode, and supports extended-data-out (EDO) DRAMs.

MAC Module The MAC unit provides high performance digital signal processing capabilities for the MCF5206e. Integrated as an execution unit in the processor's operand execution pipeline, the MAC unit implements a three-stage arithmetic pipeline with sustained instruction issue rate of one MAC cycle for 16x16 operations (while also supporting 32x32 operations). The MAC op-codes provide a full feature set of extensions to the standard ColdFire instruction set for signed and unsigned operands. In addition to executing the MAC-specific instructions, this unit also performs all integer multiply op codes, providing higher performance for this class of operation.

DMA Controller MCF5206e provides two fully programmable DMA channels for quick data transfer (32 bits, with packing and unpacking supported). Each channel has an external request pin associated with it. Single and dual address mode is supported with the ability for program bursting and cycle stealing. With auto-alignment enabled, efficient block transfers of up to 128 bits can be achieved.

MCF5206e Overview, Continued

Two UART Modules

The UART modules contain independent receivers and transmitters that are clocked by the UART internal timer. This timer is clocked by the system clock or an external clock supplied by the TIN pin. Data formats can be 5, 6, 7, or 8 bits with even, odd, or no parity, and as many as two stop bits in 1/16 increments. Four-byte receive buffers and two-byte transmit buffers minimize CPU service calls. The UART modules also provide several error-detection and maskable-interrupt capabilities. Modem support includes request-to-send (RTS) and clear-to-send (CTS) signals.

The system clock provides the clocking function via a programmable prescaler. You can select full duplex, autoecho loopback, local loopback, and remote loopback modes. The programmable UARTs can interrupt the CPU on various normal or error condition events.

Timer Module

The timer module includes two general-purpose timers, each of which contains a free-running 16-bit timer for use in any of three modes. One mode captures the timer value with an external event. Another mode triggers an external signal or interrupts the CPU when the timer reaches a set value, while a third mode counts external events. The timer unit has an 8-bit prescaler that allows programming of the clock input frequency, which is derived from the system clock. The programmable timer-output pin generates either an active-low pulse or toggles the output.

Motorola Bus (M-Bus) Module

The M-Bus interface is a two-wire, bidirectional serial bus that exchanges data between devices and is compatible with the I²C Bus standard. The M-Bus minimizes the interconnection between devices in the end system and is best suited for applications that need occasional bursts of rapid communication over short distances among several devices. Bus capacitance and the number of unique addresses limit the maximum communication length and the number of devices that can be connected.

System Interface

The MCF5206e processor provides a glueless interface to 8-, 16-, and 32-bit port size SRAM, ROM, and peripheral devices with independent programmable control of the assertion and negation of chip-selects and write-enables. Programmable address and data-hold times can be extended for a compatible interface to external devices and memory. The MCF5206e also supports bursting ROMs.

Continued on next page

MCF5206e Overview, Continued

System Interface (Continued)

External Bus Interface. The bus interface controller transfers information between the ColdFire core and memory, peripherals, or other masters on the external bus. The external bus interface provides as much as 28 bits of address bus space, a 32-bit data bus, and all associated control signals. This interface implements an extended synchronous protocol that supports bursting operations. For nonsynchronous external memory and peripherals, the MCF5206e processor provides an alternate asynchronous bus transfer acknowledgment signal.

Simple two-wire request/acknowledge bus arbitration between the MCF5206e processor and another bus master, such as a DMA device, is glueless with arbitration handled internal to the MCF5206e processor. Alternately, an external bus arbiter can control more complex three-wire (request, grant, busy) multiple-master bus arbitration, allowing overlapped bus arbitration with one clock-bus handovers.

Chip Selects. Eight programmable chip select outputs provide signals that enable external memory and peripheral circuits for automatic wait-state insertion. These signals also interface to 8-, 16-, or 32-bit ports. In addition, other external bus masters can access chip selects. The upper four chip-selects are multiplexed with A[27:24] of the address bus and the four write-enable signals. The base address, access permissions, and timing waveforms are all programmable using configuration registers.

Except for fast page mode, all operations are available to other external bus masters. The DRAM controller can generate RAS and CAS for an external master and can continue to generate refresh requests.

8-Bit Parallel Port Interface. An 8-bit general-purpose programmable parallel port serves as either an input or output on a bit-by-bit basis. The parallel port is multiplexed with PST[3:0] and DDATA[3:0] debug signals.

Interrupt Controller. The interrupt controller provides user-programmable control of three or seven external interrupt and five internal peripheral interrupts. You can program each internal interrupt to any one of seven interrupt levels and four priority levels within each of these levels. The three external interrupt signals can be configured as either fixed interrupt levels 1, 4, and 7, or as a 7-level encoded interrupt. You can also program the external interrupts to any one of the four priority levels within the respective interrupt levels.

Continued on next page

MCF5206e Overview, Continued

System Interface (Continued)

System Protection. The MCF5206e processor contains a 16-bit software watchdog timer with an 8-bit prescaler. The programmable software watchdog timer provides either a level 7 interrupt or a hardware reset on timeout. The MCF5206e processor also contains a reset status register that indicates the cause of the last reset.

JTAG. To help with system diagnostics and testing during manufacture, the MCF5206e processor includes dedicated user-accessible test logic that complies with the IEEE 1149.1 standard for boundary scan testability, often referred to as Joint Test Action Group, or JTAG. For more information, refer to the IEEE 1149.1 standard.

System Debug Interface

The ColdFire debug interface supports real-time trace and background-debug mode. A 4-pin background debug mode (BDM) interface provides system debug. The BDM is a superset of the BDM interface provided on Motorola's 683XX Family of parts.

In real-time trace, four status lines provide information on processor activity in real time (PST pins). A 4-bit wide debug data bus (DDATA) displays operand data, which helps track the machine's dynamic execution path as the change-of-flow instructions execute. These signals are multiplexed with the 8-bit parallel port for application development which does not use real-time trace.

System Diagram

Figure 2 shows the system diagram of the MCF5206e device.

MCF5206e Overview, Continued

Figure 2: MCF5206e Diagram

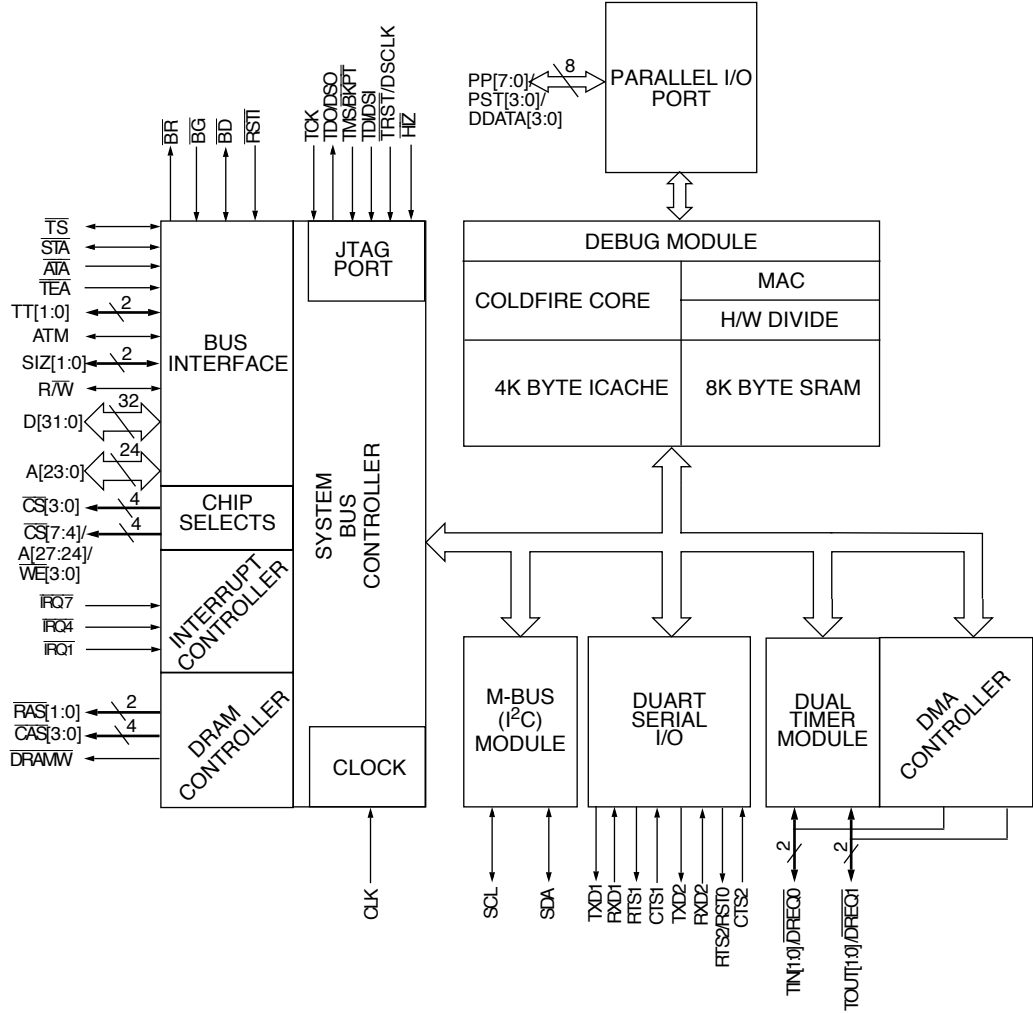

Package and Pinout

Figure 3 shows the MCF5206e pinout that is supplied in a 160-pin plastic quad flat pack.

MCF5206e Overview, Continued

Figure 3: MCF5206e Pinout Diagram

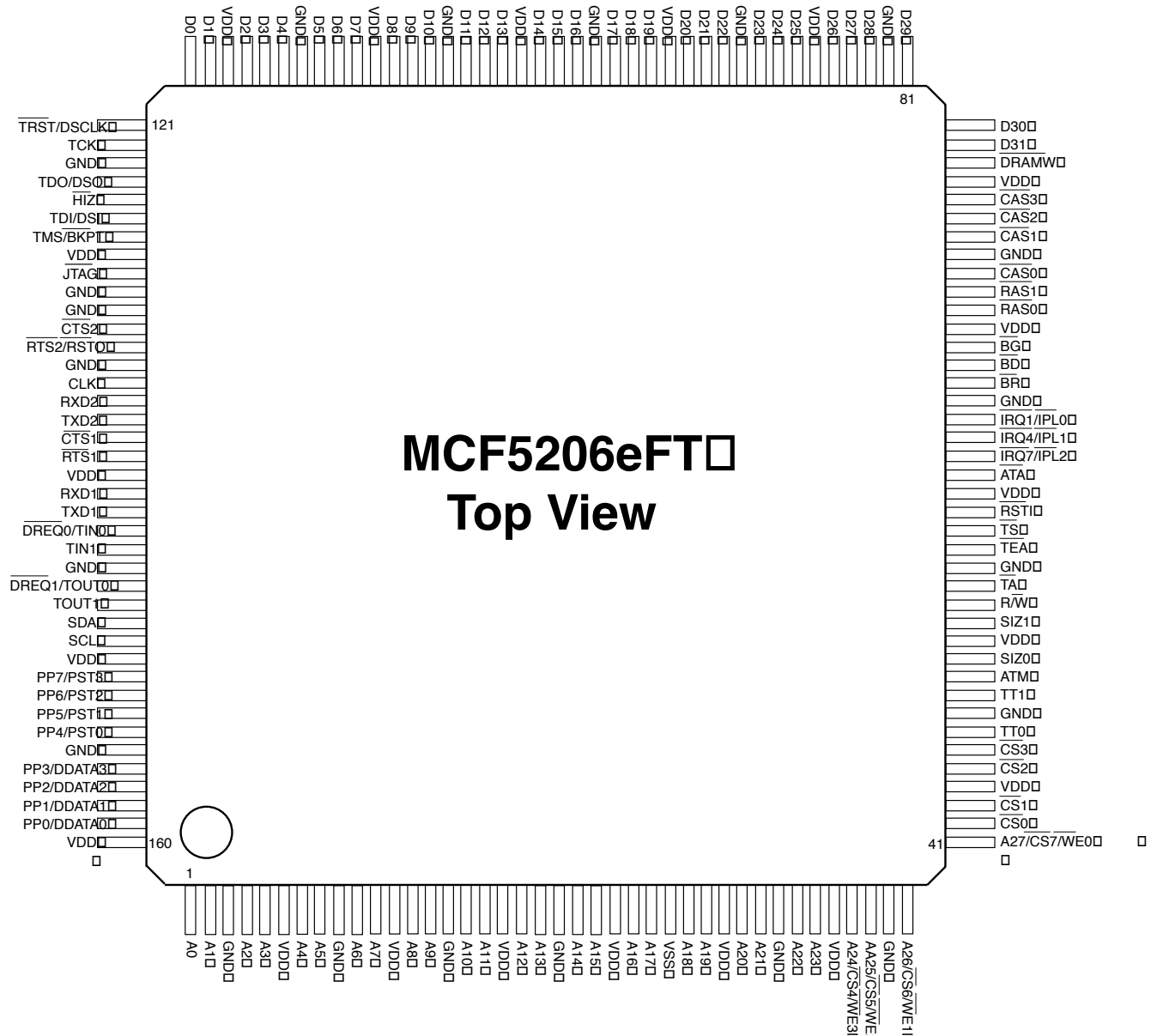

More Information

The table below identifies the packages and operating frequencies that will be available for the MCF5206e processor.

MCF5206e Package/Frequency Availability

Package	Frequency	Temperature
Plastic Quad Flat Pack 160 lead	40, and 54MHz	0 to 70 C
Plastic Quad Flat Pack 160 lead	40 MHz	-40 to +85 C

Documentation. Additional and detailed information is available from Motorola literature distribution centers.

Document Number	Document Title
MCF5206e/D	MCF5206e Product Brief (Currently available)
MCF5206eUM/AD	MCF5206e User's Manual (Est. Stocking LDC July 98)
MCF5200PRM/AD	MCF5200 ColdFire Family Programmer's Reference Manual Rev. 1.0 (Currently available)

Development Tools. Development tools for the MCF5206e processor consist of a complete suite of compilers and debuggers available from third-party developers, as shown in the tables below. Any development tool that generates code for the Motorola ColdFire MCF5206 can do the same for the MCF5206e processor.

COMPANY NAME	COMPANY PHONE NUMBER	AVAILABILITY
COMPILERS/DEBUGGERS		
Diab Data	415-571-1700	Now
Software Development Systems	708-368-0400	Now
RTOS		
Integrated Systems	408-542-1781	Now
Embedded System Products	617-828-5588	Now
Wind River Systems	510-748-4100	Now
EMULATORS		
Yokogawa/Orion Instruments	408-747-0440	Now
Embedded Support Tools (EST)	617-828-5588	Now
Noral Micrologics	508-647-1013	
Lauterbach	508-620-4521	Now
Microtek	503-645-7333	Now
LOGIC ANALYZERS		
Hewlett-Packard (preprocessors only)	719-590-2558	Now

COMPANY NAME	COMPANY PHONE NUMBER	AVAILABILITY
DEVELOPMENT BOARDS		
ORDER NUMBER		
M5206 eAN	---	September 98

Motorola reserves the right to make changes without further notice to any products herein. Motorola makes no warranty, representation or guarantee regarding the suitability of its products for any particular purpose, nor does Motorola assume any liability arising out of the application or use of any product or circuit, and specifically disclaims any and all liability, including without limitation consequential or incidental damages. "Typical" parameters can and do vary in different applications. All operating parameters, including "Typicals" must be validated for each customer application by customer's technical experts. Motorola does not convey any license under its patent rights nor the rights of others. Motorola products are not designed, intended, or authorized for use as components in systems intended for surgical implant into the body, or other applications intended to support or sustain life, or for any other application in which the failure of the Motorola product could create a situation where personal injury or death may occur. Should Buyer purchase or use Motorola products for any such unintended or unauthorized application, Buyer shall indemnify and hold Motorola and its officers, employees, subsidiaries, affiliates, and distributors harmless against all claims, costs, damages, and expenses, and reasonable attorney fees arising out of, directly or indirectly, any claim of personal injury or death associated with such unintended or unauthorized use, even if such claim alleges that Motorola was negligent regarding the design or manufacture of the part. Motorola and  are registered trademarks of Motorola, Inc. Motorola, Inc. is an Equal Opportunity/Affirmative Action Employer.

Literature Distribution Centers:

USA/EUROPE: Motorola Literature Distribution; P.O. Box 5405, Denver, Colorado 80217 1-800-675-2140

JAPAN: Nippon Motorola Ltd.; 4-32-1, Nishi-Gotanda, Shinagawa-ku, Tokyo 141 Japan

ASIA-PACIFIC: Motorola Semiconductors H.K. Ltd.; 8B Tai Ping Industrial Park, 51 Ting Kok Road, Tai Ping Industrial Estate, Tai Po, N.T., Hong Kong